

Liebert® GXT4™

500-3000VA Rack-Tower

GUIDE SPECIFICATIONS

1.0 GENERAL

1.1 SUMMARY

This specification shall define the electrical and mechanical characteristics and requirements for a continuous-duty, single-phase, solid-state uninterruptible power system (UPS). The UPS shall provide high-quality AC power for sensitive electronic equipment loads.

1.2 STANDARDS

The UPS shall be designed in accordance with applicable sections of the current revision of the following documents. Where a conflict arises between these documents and statements made herein, the statements in this specification shall govern.

120 and 208V Nominal Units

- Listed to UL Standard 1778, 4th Edition; and c-UL Listed
- CSA 22.2 No. 107.1
- ANSI C62.41, Category A, Level 3
- IEC 61000-3-2
- EN62040-2
- EN61000-4-2
- EN61000-4-3
- EN61000-4-4
- EN61000-4-5
- EN61000-4-6
- FCC Part 15, Class A
- ISTA Procedure 1A/1E
- RoHS2 (6 by 6) Compliant
- REACH and WEEE Compliant

230 Volt Nominal Units

- EN 62040-1:2008
- TUV/GS and CE compliance mark
- EN50091-1-1
- EN50091-2, Class A
- EN50082-1
- EN62040-2, 2nd Ed, Category C2
- EN61000-4-2
- EN61000-4-3
- EN61000-4-4
- EN61000-4-5
- EN61000-4-6
- EN61000-3-2
- ISTA Procedure 1A/1E
- RoHS2 (6 by 6) Compliant
- REACH and WEEE Compliant
- Listed to UL Standard 1778, 4th Edition; and c-UL Listed (700, 1000, and 3000VA models only)

1.3 SYSTEM DESCRIPTION

1.3.1 Modes of Operation

The UPS shall be designed to operate as a true on-line double-conversion system in the following modes:

- A. **Normal** - In normal operation incoming AC power shall be fed to the input power factor corrected (PFC) rectifier that converts the AC power to DC power for the inverter. In this mode, power shall also be derived from utility power for the battery charger. The inverter shall derive DC power from the PFC rectifier to regenerate filtered and regulated AC sinewave power for the connected load. The unit shall begin charging the battery once the UPS is connected to utility power, regardless of whether the UPS is ON or OFF. In the event of a utility outage or severe abnormality (sag or swell), the inverter shall support the connected load from battery power until the battery is discharged or the utility power returns, whichever occurs first.
- B. **Battery** - Upon failure of utility / mains AC power, the critical AC load shall be supplied by the inverter, which obtains power from the battery. There shall be no interruption in power to the critical load upon failure or restoration of the utility / mains AC source.
- C. **Recharge** - Upon restoration of utility / mains AC power, after a utility / mains AC power outage, the input converter shall automatically restart and resume supplying power to the inverter and the battery charger to recharge the battery.
- D. **Automatic Restart** - Upon restoration of utility / mains AC power, after a utility / mains AC power outage and complete battery discharge, the UPS shall automatically restart and resume supplying power to the critical load and the battery charger automatically recharges the battery. This feature shall be capable of being disabled by the user.
- E. **Bypass** - The integral bypass shall perform an automatic transfer of the critical AC load from the inverter to the bypass source, in the event of an overload, PFC failure, internal over temperature, DC bus overvoltage or inverter failure conditions.
- F. **ECO** – The UPS shall allow the user to enable and place the UPS in ECO mode of operation to reduce electrical consumption. The ECO mode operation shall be an Active type, whereas the UPS will power the connected equipment through the bypass path and the UPS inverter shall be on and operating at no load in order to stay synchronized to the bypass to ensure rapid transfers to inverter power when input power falls outside of the user customizable parameters. The UPS shall also have a user customizable requalification time that input power must remain within the ECO mode parameters before transferring back to ECO operation. This is to minimize the number of transfers between bypass and inverter.

1.3.2 Design Requirements

A. Voltage

Input/output voltage specifications of the UPS shall be:

Input

- **120V units:** 0 - 140VAC, 50/60Hz, single-phase, 2-wire-plus-ground.
- **208V units:** 0 - 280VAC, 50/60Hz, single-phase, 2-wire-plus-ground.
- **230V units:** 0 - 280VAC, 50/60Hz, single-phase, 2-wire-plus-earth.

Output

- **120V units:** 120VAC (user configurable: 110V, 115V, 120V, 127V) $\pm 3\%$, 50/60Hz, single-phase, 2-wire-plus-ground.
- **208V units:** 208VAC (user configurable: 208V, 220V, 230V, 240V) $\pm 3\%$, 50/60Hz, single-phase, 2-wire-plus-ground.
- **230V units:** 230VAC (user configurable: 220V, 230V, 240V) $\pm 3\%$, 50/60Hz, single-phase, 2-wire-plus-earth.

B. Output Load Capacity

Specified output load capacity of the UPS shall be:

- 500VA/450 Watts at 0.9 lagging power factor.
- 700VA/630 Watts at 0.9 lagging power factor.
- 1000VA/900 Watts at 0.9 lagging power factor.
- 1500VA/1350 Watts at 0.9 lagging power factor.
- 2000VA/1800 Watts at 0.9 lagging power factor.
- 3000VA/2700 Watts at 0.9 lagging power factor.

C. Internal Battery

The UPS shall utilize valve-regulated, non-spillable, lead acid cells.

D. Reserve Time

- **500VA:** 17 minutes
- **700VA:** 11 minutes (120V or 230V)
- **1000VA:** 7 minutes (120V); 3 minutes (230V)
- **1500VA:** 6 minutes (120V or 230V)
- **2000VA:** 3 minutes (120V or 230V)
- **3000VA:** 3 minutes (120V or 208V or 230V)

These times shall be at full load with ambient temperature of 77°F (25°C) with resistive loading.

E. Battery Recharge

The UPS shall contain a three-stage battery charger designed to prolong battery life. Recharge time for UPS internal batteries shall be 5 hours (for 500, 700, 1000, 2000, and 3000VA models) and 6 hours (for 1500VA models) to 90% capacity after a complete discharge with full load connected.

1.3.3 Performance Requirements

1.3.3.1 AC Input to UPS

- A. Voltage Configuration:** The UPS shall incorporate a variable input voltage window feature that shall operate at the values in the following table, without drawing power from the batteries.

Load Level	500-1000 VA 120 VAC Input Voltage	1500-3000 VA 120 VAC Input Voltage	3000 VA 208 VAC Input Voltage	700-2000 VA 230 VAC Input Voltage	3000 VA 230 VAC Input Voltage
100%	90 VAC	102 VAC	177 VAC	177 VAC	196 VAC
90%	86 VAC	96 VAC	168 VAC	168 VAC	184 VAC
80%	81 VAC	90 VAC	159 VAC	159 VAC	173 VAC
70%	77 VAC	84 VAC	150 VAC	150 VAC	161 VAC
60%	73 VAC	78 VAC	142 VAC	142 VAC	150 VAC
50%	69 VAC	72 VAC	133 VAC	133 VAC	138 VAC
40%	64 VAC	66 VAC	124 VAC	124 VAC	127 VAC
30%	60 VAC	60 VAC	115 VAC	115 VAC	115 VAC

- B. Frequency:** UPS shall auto-sense input frequency when first powered up and shall operate within the following frequency specifications. UPS shall be capable of cold start with default frequency of 60Hz (120VAC and 208VAC units) and 50Hz (230VAC units). Once started the frequency operating window shall be 40-70Hz.

Three frequency settings shall be available in the Liebert GXT4 Configuration program: Auto frequency sensing (factory default setting), 50Hz frequency conversion and 60Hz frequency conversion.

- C. Input Power Factor:** >0.99 lagging at rated load.
- D. Input Current reflected distortion:** 5% THD typical.
- E. Input Current Ratings**

UPS Model #	120VAC Units	230VAC Units	208VAC Units
500RT	4.2A	N/A	N/A
700RT	5.8A	2.9A	N/A
1000RT	8.3A	3.9A	N/A
1500RT	12A	5.9A	N/A
2000RT	16A	7.8A	N/A
3000RT	24A	11.7A	N/A
3000RT208	N/A	N/A	12.9A

F. Inrush Current (initial startup, no load): The UPS shall have a maximum inrush current of 6 times the full load peak input current.

G. Input Line Transient Immunity: UPS shall conform to an input line transient conforming to IEEE C62.41, Category A, Level 3 tests for 120VAC and 208VAC models. The 230VAC models shall meet EN61000-4-5.

H. Surge Protection

- **120VAC units:** MOV ratings shall be 175V, 80 Joules minimum connected L-N.
- **208VAC units:** MOV ratings shall be 320V, 80 Joules minimum connected L1-L2, L1-G and L2-G.
- **230VAC units:** MOV ratings shall be 320V, 80 Joules minimum connected L-N.

1.3.3.2 AC Output, UPS Inverter

A. Voltage Configuration

- **120V units:** 120VAC, 50/60Hz, single-phase, 2-wire-plus-ground, configuration program selectable (110V, 115V, 120V, 127V).
- **208V units:** 208VAC, 50/60Hz, single-phase, 2-wire-plus-ground, configuration program selectable (208V, 220V, 230V, 240V).
- **230V units:** 230VAC, 50/60Hz, single-phase, 2-wire-plus-earth, configuration program selectable (220V, 230V, 240V).

B. Voltage Regulation

± 3% steady state.

C. Frequency Regulation

±5% synchronized to utility / mains. ±0.1Hz free running or on-battery operation.

D. Frequency Slew Rate

1.0Hz per second maximum

E. Voltage Distortion

<3% total harmonic distortion (THD) typical into a 100% linear load, <5% THD typical into a 100% non-linear load with crest factor ratio of 3:1.

F. Load Power Factor Range

The load power factor range shall be 0.65 lagging to 1.0 (unity) without power derating.

G. Output Power Rating

Output power rating shall be 500VA/450 Watts, 700VA/630 Watts, 1000VA/900 Watts, 1500VA/1350 Watts, 2000VA/1800 Watts and 3000VA/2700 Watts at 0.9 lagging power factor.

H. Inverter Overload Capability

	500VA - 2000VA	3000VA
120V / 208V	105% to 125% - 60 seconds 125% to 150% - 50 seconds 150% to 200% - 2 seconds >200% - 250ms	105% to 125% - 15 seconds 125% to 150% - 10 seconds 150% to 200% - 2 seconds >200% - 250ms
230V	105% to 125% - 60 seconds 125% to 150% - 50 seconds 150% to 200% - 2 seconds >200% - 250ms	105% to 125% - 55 seconds 125% to 150% - 55 seconds 150% to 200% - 2 seconds >200% - 250ms

I. Voltage Transient Response

- ±7% in line mode 0-100-0 % loading of the UPS
- ±7% in battery mode for 0-100-0% loading of the UPS rating.

J. Transient Recovery Time

To nominal voltage within 90 milliseconds.

K. AC-AC Efficiency:

The 700VA-3000VA 120V; 3000VA 208V; and 700-3000VA 230V UPS models shall be EPA ENERGY STAR qualified and labeled

- **500RT120:** 88% AC –AC at full rated linear load
- **700RT120:** 89% AC –AC at full rated linear load
- **1000RT120:** 88% AC –AC at full rated linear load
- **1500RT120:** 89% AC –AC at full rated linear load
- **2000RT120:** 89% AC –AC at full rated linear load
- **3000RT120:** 89% AC –AC at full rated linear load

- **3000RT208:** 90% AC –AC at full rated linear load

- **700RT230:** 89% AC –AC at full rated linear load
- **1000RT230:** 89% AC –AC at full rated linear load
- **1500RT230:** 90% AC –AC at full rated linear load
- **2000RT230:** 91% AC –AC at full rated linear load
- **3000RT230:** 90% AC –AC at full rated linear load

L. Programmable & Controllable Outlets:

The UPS units shall have 2 groups of programmable and controllable outlets. These shall be user customizable to program to perform load shedding based upon battery capacity remaining, time on battery operation, battery time remaining, and overload condition when on battery power. The user shall also be able to program these groups for sequential restart of connected equipment based upon time after input power is restored. The user can also program these to always be turned off to prevent unauthorized equipment from being plugged into the UPS.

1.4 ENVIRONMENTAL CONDITIONS

A. Ambient Temperature

Operating: The ambient temperature range, when UPS is operational, shall be from 32°F to 77°F (0°C to 25°C). There shall not be any degradation in the performance when operating in this range. Automatic derating shall occur for operation in higher ambient temperatures based on the following table.

Ambient Temperature	78-86°F ±5°F (26-30°C ±3°C)	87-95°F ±5°F (31-35°C ±3°C)	96-104°F ±5°F (36-40°C ±3°C)
Max Output Power Factor degradation @ max load	100%-93%	92%-86%	85%-79%

Storage: 5°F to 122°F (-15°C to 50°C)

B. Relative Humidity

Operating: 0 to 95% non-condensing.

Storage: 0 to 95% non-condensing.

C. Altitude

10,000 ft. (3,000m) max., without power derating when operated within the temperature specified in Section 1.4, Item A. Ambient temperature shall be derated 9°F (5°C) for each additional 1600 ft. (500m) above 10,000 ft. (3,000m).

D. Audible Noise

The audible noise of the UPS shall be:

- **500/700/1000VA:** <43dBA max @ 1 meter from front, sides, and rear
- **1500VA:** <45dBA max @ 1 meter from front and sides, <46dBA max @ 1 meter from rear
- **2000VA - 3000VA:** <48dBA max @ 1 meter from front sides, and rear

E. Electrostatic Discharge

The UPS shall be able to withstand an electrostatic discharge compliant to ENC61000-4-2.

1.5 USER DOCUMENTATION

The specified UPS system shall be supplied with a Safety Instruction & Warning Sheet. The specified UPS system shall be supplied with quick start guides for ease of installation and UPS start up. Each UPS will also contain a full user manual located on the included CD. The user manual shall include installation instructions, a functional description of the equipment with block diagrams, safety precautions, illustrations, step-by-step operating procedures and general maintenance guidelines. The included CD will also include a configuration program to allow user customization of UPS operating parameters and also UPS monitoring and computer/server shutdown software.

1.6 WARRANTY

The UPS manufacturer shall warrant the UPS against defects in materials and workmanship for two (2) years. The no-hassle replacement warranty shall include shipping costs to the customer site for the new replacement unit and shipping costs from the customer site for the return of the failed unit. Optional one (1) and three (3) year full coverage extension warranties shall be available from the manufacturer. The manufacturer's standard and extended warranties shall cover all parts, including the battery.

1.7 QUALITY ASSURANCE

1.7.1 Manufacturer Qualifications

More than 40 years' experience in the design, manufacture, and testing of solid-state UPS systems shall be required. The manufacturer shall be certified to ISO 9001:2008.

1.7.2 Factory Testing

Before shipment, the manufacturer shall fully and completely test the system to ensure compliance with the specification.

2.0 PRODUCT

2.1 FABRICATION

All materials and components making up the UPS shall be new, of current manufacture and shall not have been in prior service except as required during factory testing. All relays shall be provided with dust covers.

2.1.1 Wiring

Wiring practices, materials and coding shall be in accordance with the requirements the standards listed in Section 1.2 and other applicable codes and standards. All wiring shall be copper.

2.1.2 Cabinet

The UPS unit shall be composed of: input PFC converter, IGBT inverter, battery charger, input filter and internal bypass circuit; and batteries consisting of the appropriate number of sealed battery cells; and shall be housed in a rack-tower NEMA type 1 enclosure and shall meet the requirements of IP20. The UPS cabinet shall be cleaned, primed and painted RAL 7021 Black.

Unit dimensions and weights shall be (*rack mount orientation*):

Model	Dimensions W x D x H, in. (mm)	Weight lb. (kg)
500RT	16.9 x 16.2 x 3.4 (430 x 408 x 85)	40.0 (18.2)
700RT	16.9 x 16.2 x 3.4 (430 x 408 x 85)	40.0 (18.2)
1000RT	16.9 x 16.2 x 3.4 (430 x 408 x 85)	40.0 (18.2)
1500RT	16.9 x 19.7 x 3.4 (430 x 497 x 85)	54.6 (24.8)
2000RT	16.9 x 19.7 x 3.4 (430 x 497 x 85)	56.1 (25.5)
3000RT	16.9 x 23.7 x 3.4 (430 x 602 x 85)	71.4 (32.4)

2.1.3 Cooling

The UPS shall be forced-air cooled by an internally mounted, continuously operating fan. Fan power shall be provided from the internal DC supply. Air intake shall be through the front of the unit and exhausted out the rear of the unit.

2.2 COMPONENTS

2.2.1 Input Converter

2.2.1.1 General

Incoming AC power shall be converted to a regulated DC output by the input converter supplying DC power to the inverter. The input converter shall provide input power factor correction (PFC) and input current distortion reduction.

2.2.1.2 AC Input Current Limit

The input converter shall be provided with AC input current limiting whereby the maximum input current is limited to 125% of the full load input current rating.

2.2.1.3 Input Protection

The UPS shall have built-in protection against under voltage, over current and overvoltage conditions including low-energy lightning surges, introduced on the primary AC source. The 120 and 208VAC models shall be able to sustain input surges without damage per criteria listed in ANSI C62.41, Category A, Level 3. The 230VAC UPS shall be able to sustain input surges without damage per criteria listed in EN61000-4-5. The 120V, 208V and 230V models shall have resettable circuit breakers.

2.2.1.4 Battery Recharge

The UPS shall contain a three-stage battery charger designed to prolong battery life. Recharge time for the internal UPS batteries shall be 5 hours (500/700/1000/2000/3000VA models) and 6 hours (1500VA models) maximum to 90% capacity (full load discharge rate). There shall be DC overvoltage protection so that if the DC voltage exceeds the pre-set limit, the UPS will shut down automatically and the critical load will be transferred to bypass.

2.2.2 Inverter

2.2.2.1 General

The UPS inverter shall be a pulse-width-modulated (PWM) design capable of providing the specified AC output. The inverter shall convert DC power from the input converter output or the battery into precise sinewave AC power for supporting the critical AC load.

2.2.2.2 Overload

The inverter shall be capable of supplying current and voltage for overloads exceeding 100% and up to 200% of full load current. A visual indicator and audible alarm shall indicate overload operation. For greater currents or longer time duration, the inverter shall have electronic current-limiting protection to prevent damage to components. The inverter shall be self-protecting against any magnitude of connected output overload. Inverter control logic shall sense and disconnect the inverter from the critical AC load without the requirement to clear protective devices.

2.2.2.3 Inverter DC Protection

The inverter shall be protected by the following DC shutdown levels:

- DC Overvoltage Shutdown
- DC Under voltage Shutdown (End of Discharge)
- DC Under voltage Warning (Low Battery Reserve); factory default set at 2 minutes (user configurable 2 to 30 minutes).

2.2.2.4 Output Frequency

An oscillator shall control the output frequency of the UPS. The inverter shall maintain the output frequency to ± 0.1 Hz of nominal frequency during Battery mode, Frequency Converter mode or when otherwise not synchronized to the utility/mains source.

2.2.2.5 Output Protection

The UPS inverter shall employ electronic current limiting circuitry.

2.2.2.6 Battery Over Discharge Protection

To prevent battery damage from over discharging, the UPS control logic shall automatically raise the shutdown voltage set point; depending on output load and connected battery system at the onset of battery operation.

2.2.3 Display and Controls

2.2.3.1 General

The UPS shall be provided with a microprocessor-based unit status display and controls section designed for convenient and reliable user operation. The monitoring functions such as voltages, currents, UPS status and alarm indicators shall be displayed on an LCD display.

2.2.3.2 System Indicators

UPS display shall also include LED based system indicators. The system level indicators shall be: fault indicator, battery indicator, inverter indicator, bypass indicator, ECO mode indicator, and indicators for the two controllable outlet groups.

- **Fault Indicator:** 1 Red LED shall illuminate if the UPS has detected a fault; and shall be Off if there is no internal fault
- **Inverter Indicator:** 1 Green LED shall illuminate when the inverter is supplying power; and shall be Off when the inverter is not supplying power
- **Battery Indicator:** 1 Amber LED shall illuminate when the battery is supplying power; and shall be Off when the battery is not supplying power
- **Bypass Indicator:** 1 Amber LED shall illuminate when the bypass is supplying power; shall be Off when the inverter is not supplying power; and shall flash when utility power is outside bypass operating specifications
- **Programmable Outlet 1 Indicator:** 1 Green LED shall illuminate when the programmable outlet is supplying power and shall be Off when the outlet is not supplying power
- **Programmable Outlet 2 Indicator:** 1 Green LED shall illuminate when the programmable outlet is supplying power and shall be Off when the outlet is not supplying power
- **ECO Mode Indicator:** 1 Green LED shall illuminate when the UPS is operating in active ECO mode operation and shall be Off when the UPS is operating in the normal double conversion mode of operation

2.2.3.3 Controls

UPS startup and shutdown operations shall be accomplished by using push buttons on the front panel of the UPS. The display shall be menu driven navigation and use four control buttons for ease of navigation and selection of the configurable parameters.

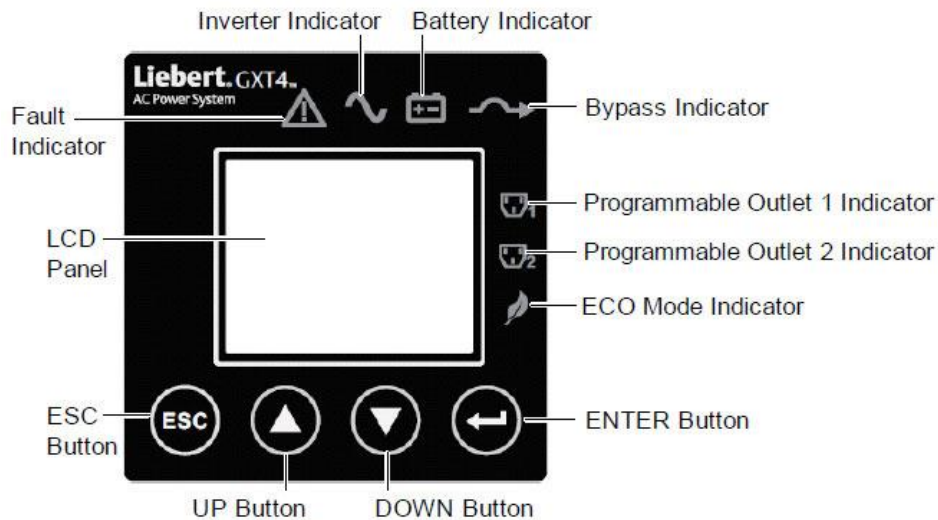

2.2.3.3.1 Control Buttons

The UPS display control button functionality shall be as follows:

ESC button: This button shall return to the previous menu or abort any change before confirming the change

UP arrow button: This button shall move the cursor up or increase the value displayed when changing parameters. This button shall also be used to scroll up for navigating the screens

DOWN arrow button: This button shall move the cursor down or decrease the value displayed when changing parameters. This button shall also be used to scroll down for navigating the screens

ENTER button: This button shall enter the next level menu or confirm the parameter changes

2.2.3.3.2 Display Menu Structure

The UPS display shall have the following menu structure with the following status and configuration screens

2.2.3.3.2.1 System Status (Default screen)

The system status screen shall be the default screen to display the input voltage, frequency, and amperage; output voltage, frequency, and amperage; battery capacity and estimated battery time remaining; loading percentage. To prolong display life, the UPS LCD display shall go into “sleep” mode after two minutes of no user interaction. Pressing the ENTER shall wake up the display and this action shall not perform any operation.

2.2.3.3.2.2 Main Menu

The main menu shall list the submenu selections:

- UPS Status Screens
- Configuration Settings Screens
- Control Settings Screens
- Event Log
- About
- Network

2.2.3.3.2.3 UPS Status

The UPS status screens shall provide the following information:

Output

- Voltage
- Frequency
- Amperage
- Power (KWH)

Load

- Capacity
- Wattage
- Volt-Amperes

Input

- Voltage
- Frequency
- Amperage
- Power (KWH)

Battery

- Capacity
- Runtime (minutes)
- Voltage

Time Since Startup

- Days / Hours / Minutes

2.2.3.3.2.4 Configuration

The UPS Configuration screens shall provide the following customizable parameters: (default values are listed first)

UPS

Audible Alarm (ON/OFF)

Startup on Bypass (NO/YES)

Guarantee Shutdown (YES/NO)

Enable Auto Restart (YES/NO)

Output Frequency Selection (Auto bypass Enable/Auto bypass disable/50Hz no bypass/60Hz no bypass)

Output Voltage Selection (110/115/120/127V for 120V models); (200/220/230/240V for 208 and 230V models)

Battery

External Battery Cabinets (0/1/2/3/4/5/6)

Low Battery Warning (2 to 30 minutes in 1 minute increments)

Battery Test Interval (8, 12, 16, 20, 26 weeks, Disable)

Battery Replacement Reminder (Year/Month/Day)

ECO Mode

ECO Mode (OFF/ON)

Voltage Tolerance ($\pm 10\%$, $\pm 5\%$, $\pm 15\%$)

Frequency Tolerance ($\pm 3\text{Hz}$, $\pm 2\text{Hz}$, $\pm 1\text{Hz}$)

Requalification Time (5min, 15min, 30min)

Outlet Group 1

The programmable outlet group 1 screens shall provide the following customizable parameters: (default values are listed first)

Outlet Control

Turn OFF

Reboot

Turn ON (if was turned off)

Outlet Settings

Turn ON Delay (0-30 minutes)

Turn OFF on battery when output is overloaded (OFF/ON)

Turn OFF when on battery power (0-30 minutes)

Turn OFF when on battery time remaining (3, settable 0-30 minutes)

Turn OFF when on battery capacity (20-80 %)

Turn ON when on input power returns (0-30 minutes)

Outlet Group 2

The programmable outlet group 2 screens shall provide the following customizable parameters: (default values are listed first). There shall be a quick way to program group 2 the same as group 1 (NO/YES) or group 2 shall be capable of having different settings from group 1

Outlet Control

- Turn OFF
- Reboot
- Turn ON (if was turned off)

Outlet Settings

- Turn ON Delay (0-30 minutes)
- Turn OFF on battery when output is overloaded (OFF/ON)
- Turn OFF when on battery power (0-30 minutes)
- Turn OFF when on battery time remaining (3, settable 0-30 minutes)
- Turn OFF when on battery capacity (20-80 %)
- Turn ON when on input power returns (0-30 minutes)

LCD Settings

- Language, English (one other that is programmable using the included CD and configuration program)
- Color (background color), Blue, Black, Red, Pink

Factory Settings

The factory settings screens shall provide a NO/YES selection to reset the UPS back to all factory setting

2.2.3.3.2.5 Control Settings

The UPS shall have the following controls from the display:

UPS ON/OFF

- Turn UPS ON
- Turn UPS OFF
- Turn ON Bypass (manually transfer to bypass power)

Audible Alarm

- Turn audible alarm ON (test alarm)
- Turn audible alarm OFF (alarm silence)

Battery Test

- Start manual battery test
- Cancel manual battery test
- View last battery test results

2.2.3.3.2.6 Event Log

The UPS shall be have an event log to record 255 events and shall be viewable from the display:

View Log

Navigate the event log to view the last 255 events.

Clear Log

User shall be able to clear the event log

The event log once full will begin to replace the first event logged to provide a FIFO process for maintaining event history. The event history shall record and display the number of events out of the 255 (xxx/255) as well as the time (days, hours, mins) from when viewing the event and the event that occurred.

2.2.3.3.2.7 About

The UPS shall be have an about screen to display the UPS model number, serial number, hardware version, and firmware version

2.2.3.3.2.8 Network

The UPS shall be have the ability to display the network information of the SNMP web card when installed. Information available shall be MAC address and IP address

2.2.3.4 Automatic Battery Test

The UPS shall feature an automatic battery test with the factory default test interval set at every eight weeks. The battery test shall ensure the capability of the battery to supply power to the inverter while loaded. If the battery fails the test, the UPS shall display a warning message to indicate the internal batteries need replaced. The battery test feature shall be user accessible by the push button on the front of the unit and with communication software. The Automatic Battery test feature shall be capable of being disabled or configured to operate every 8, 12, 16, 20, 26 weeks through the UPS Configuration Program or from the LCD display.

2.3 BYPASS

2.3.1 General

A bypass circuit shall be provided as an integral part of the UPS. The bypass control logic shall contain an automatic transfer control circuit that senses the status of the inverter logic signals and operating and alarms conditions. This control circuit shall provide a transfer of the load to the bypass source if available and if the inverter is capable of powering the load (i.e., if there is an overload condition, if the unit is in Manual Bypass mode or if the voltage or frequency is out of tolerance).

2.3.2 Automatic Transfers

The transfer control logic shall activate the bypass automatically, transferring the critical AC load to the bypass source, after the transfer logic senses one of the following conditions:

- UPS overload
- UPS over temperature
- PFC failure
- Inverter failure
- DC bus overvoltage

Once the overload condition is reduced, the load shall be automatically transferred back to inverter power.

2.4 INTERNAL BATTERY

Valve-regulated, non-spillable, lead acid cells (VRLA) shall be used as a stored-energy source for the specified UPS system. The battery shall be housed internal to the UPS cabinet and sized to support the inverter at rated load and power factor, with ambient temperature of 25°C (77°F) for a minimum of 3 minutes reserve time. The expected life of the battery shall be 3-5 years or a minimum 260 complete discharge cycles. The UPS units have the capability to allow the operator to replace the internal battery.

All UPS models shall allow connection of up to six external battery cabinets to provide extended run time capability. External battery cabinets shall match the UPS in aesthetics and color.

2.5 OUTPUT DISTRIBUTION

Output distribution shall be integral to the UPS and located on the rear of the unit. There shall be 2 groups of the identified outlets listed below that are programmable and controllable as defined in this specification

Model	120VAC Units	230VAC Units	208VAC Units
500RT	(6) NEMA 5-15R	N/A	N/A
700RT	(6) NEMA 5-15R	(6) EN60320/C13	N/A
1000RT	(6) NEMA 5-15R	(6) EN60320/C13	N/A
1000MT	(6) NEMA 5-15R	N/A	N/A
1500RT	(6) NEMA 5-15R	(6) EN60320/C13	N/A
2000RT	(6) 5-15/20R (T-Slot)	(6) EN60320/03	N/A
3000RT	(6) 5-15/20R (T-Slot) (1) NEMA L5-30R	(6) EN60320/03 (1) EN60320/09	(2) NEMA L6-15R (1) NEMA L6-20

2.6 COMMUNICATION OPTIONS

2.6.1.1 Liebert IntelliSlot® Communication

The UPS shall include one Liebert IntelliSlot communication port to allow the operator to field-install an optional Liebert IntelliSlot communication card. A Liebert IntelliSlot card may be installed during any state of UPS operation (On, Standby or Off states). Available Liebert IntelliSlot options are described below.

Liebert IntelliSlot Web Card (IS-WEBCARD)

The optional Liebert IntelliSlot Web Card shall deliver SNMP and Web management to the UPS when connected to any 10 or 100 Mbit Ethernet network. The card shall support 10 and 100 Mbit Ethernet and shall provide for in-the-field upgrade of SNMP firmware. The kit shall include the Liebert IntelliSlot card, MIB, configuration cable and user manual.

Liebert IntelliSlot Relay Interface Card (IS-RELAY)

The optional Liebert IntelliSlot Relay Interface Card shall provide contact closure for remote monitoring of alarm conditions in the UPS, delivering signals for On Battery, On Bypass, Low Battery, Summary Alarm, UPS Fault and On UPS. The contacts shall be rated for 24VAC or 24VDC at 1A. Connections shall be to a terminal block connector with cable provided by the end user.

Liebert IntelliSlot Multiport Card (IS-MULTIPOINT)

The optional Liebert IntelliSlot Multiport Card shall provide 4 sets of contact closure for remote monitoring of alarm conditions in the UPS, delivering signals for On Battery and Low Battery for connection to up to 4 servers/computers for use with Liebert MultiLink Shutdown software. The contacts shall be rated for 24VAC or 24VDC at 1A. Connections shall be to a terminal block connector with cable provided by the end user.

2.6.1.2 Terminal Block Connections

The UPS shall contain on the rear panel a terminal block to provide low voltage signals for On Battery, Low Battery, Any Mode Shutdown and Battery Mode Shutdown

Any-Mode Shutdown

The purpose of Any-Mode Shutdown shall be to shut down the UPS output by turning Off the rectifier, inverter and bypass so that there is no power to the loads.

Any-Mode Shutdown can be operated locally and remotely, as described as follows:

- Local Any-Mode Shutdown can be performed by shorting Pin 1 and Pin 2
- Remote Any-Mode Shutdown can be performed by a switch connected to Pin 1 and Pin 2 and mounted at a remote location.

Remote Power Off shall be performed either by NO or NC contact of Any-Mode Shutdown, depending on the settings in the configuration program.

A current-limited source (+12VDC, 50mA) shall be available from the UPS.

The connection to the UPS for remote connection shall be via terminal block connector.

Any-Mode Shutdown wiring shall conform to all national, regional and local wiring regulations.

Battery Mode Shutdown

Battery Mode Shutdown shall permit shutting down the UPS by turning Off the rectifier, inverter and bypass so that there is no power to the load when the UPS is On Battery. Battery Mode Shutdown can be performed locally or remotely:

- Local Any-Mode Shutdown can be performed by shorting Pin 3 and Pin 4.
- Remote Any-Mode Shutdown can be achieved by a switch connected to Pin 3 and Pin 4 and mounted at a remote location.

On Battery

On Battery signal shall be a Normally Open (NO) dry contact. When the UPS is supplying output power from the battery this dry contact shall be closed.

Low Battery

Low Battery signal shall be a Normally Open (NO) dry contact. When the UPS is supplying output power from the battery and has reached the Low Battery Warning time selected in the configuration program, this dry contact shall be closed.

The rated values for the dry contacts shall be:

- Rated Voltage: 5V
- Working Voltage Range: 4.5-10V
- Rated Current: 30mA

2.6.1.3 USB Port

The USB port shall allow connection to a computer to use with Liebert MultiLink[®] shutdown software and for use with the UPS configuration program. The USB port shall be HID1 compliant and shall work with the Power Management system in Microsoft[®] Windows[®] XP or later, Linux and Mac OS X[®].

2.6.1.4 Serial Port

A serial port shall be made available with a DB9F connector on the rear of the UPS. This connector shall communicate using Emerson proprietary protocol for use with Liebert MultiLink shutdown software. This port will provide more data points for use with MultiLink that is not part of the USB HID1 protocol

2.7 LIEBERT GXT4 CONFIGURATION PROGRAM

An included Microsoft Windows-based (Windows XP or later) Configuration Program and cable shall allow configuration of UPS features and operating parameters to meet specific application requirements, if required. Options that are configurable via this program shall include:

- Select one of five input/output voltages to match voltages found around the world.
- Enable / Disable Auto-Restart.
- Disable the Line-Neutral-Reversal/Missing-Ground receptacle wiring alarm.
- Select frequency converter operation with a fixed output frequency of 50 or 60Hz.
- Set the Low Battery Warning alarm time from 2 to 30 minutes.
- Disable the Auto-Battery test.
- Set the Auto-Battery test to 8, 12, 16, 20, 26 weeks or Disable the test.
- Select the number of external battery cabinets connected to the UPS to adjust the remaining run-time calculations reported by the UPS Liebert software products.
- Program the outlet groups individually
- Configure the unit for ECO mode operation
- Change the LCD display language